

iCON
BESS for C&I

All-in-One Cabinet
SU215E100LM



**New
2024**

Highlights

- 100kW converter and 215kWh battery
- Flexible layout up to 5 cabinets in parallel
- Turnkey solution with PCS and batteries in one cabinet

System Features



Plug-and-Play



No external PCS



No BCP needed



Liquid-cooled



Up to 5 cabinets



Flexible layout

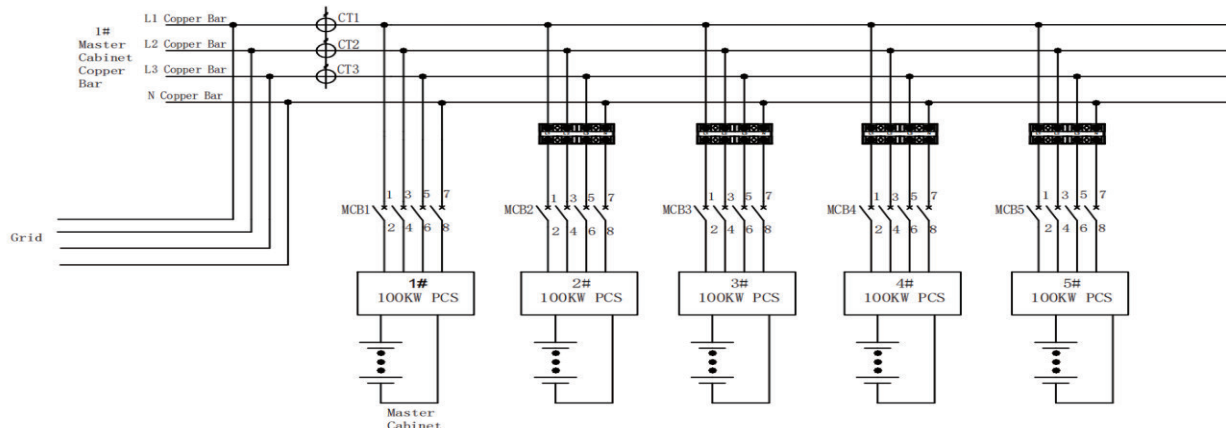

Technical Specifications

System Model	SU215E100LM
System Information	
Nominal Power	100kW
Nameplate Capacity	215kWh
Battery Information	
Battery Chemistry	LFP
Capacity	280Ah
Configuration	240S1P
Nominal Voltage	768V
Voltage Range	672~864V
Charge and Discharge Rate	≤0.5
Depth of Discharge	98%
PCS Information	
Nominal Power	100kVA
Operating Mode	Support Grid-Connected & Off-Grid Operation
Nominal Grid / Islanding Voltage	400Vac
Power Factor	-1 to 1
Nominal Grid Frequency	50Hz
Isolation	No Isolation
Connection Method	3P4L
Working Conditions	
Degree of Protection	IP55
Noise Emission	≤75dB @1M
Operating Temperature Range	-25°C~45°C
Relative Humidity	0~95% (Non-Condensing)
Max.Working Altitude	3000m
System Information	
Dimensions(W×H×D)	1000×2500×1350mm
Weight	2500kg
Cooling	Intelligent Liquid Cooling
PCS Cooling	Forced Air Cooling
Fire Suppression System	Aerosol+Water
Communication Protocol	CAN/485
Certification	UL1973, UL9540A, IEC62619, IEC61000, GB/T36276, 62933



C&I Sales Manager - Stacy Si

✉ ciess@risenenergy.com